

8 7 6 5 4 3 2 1

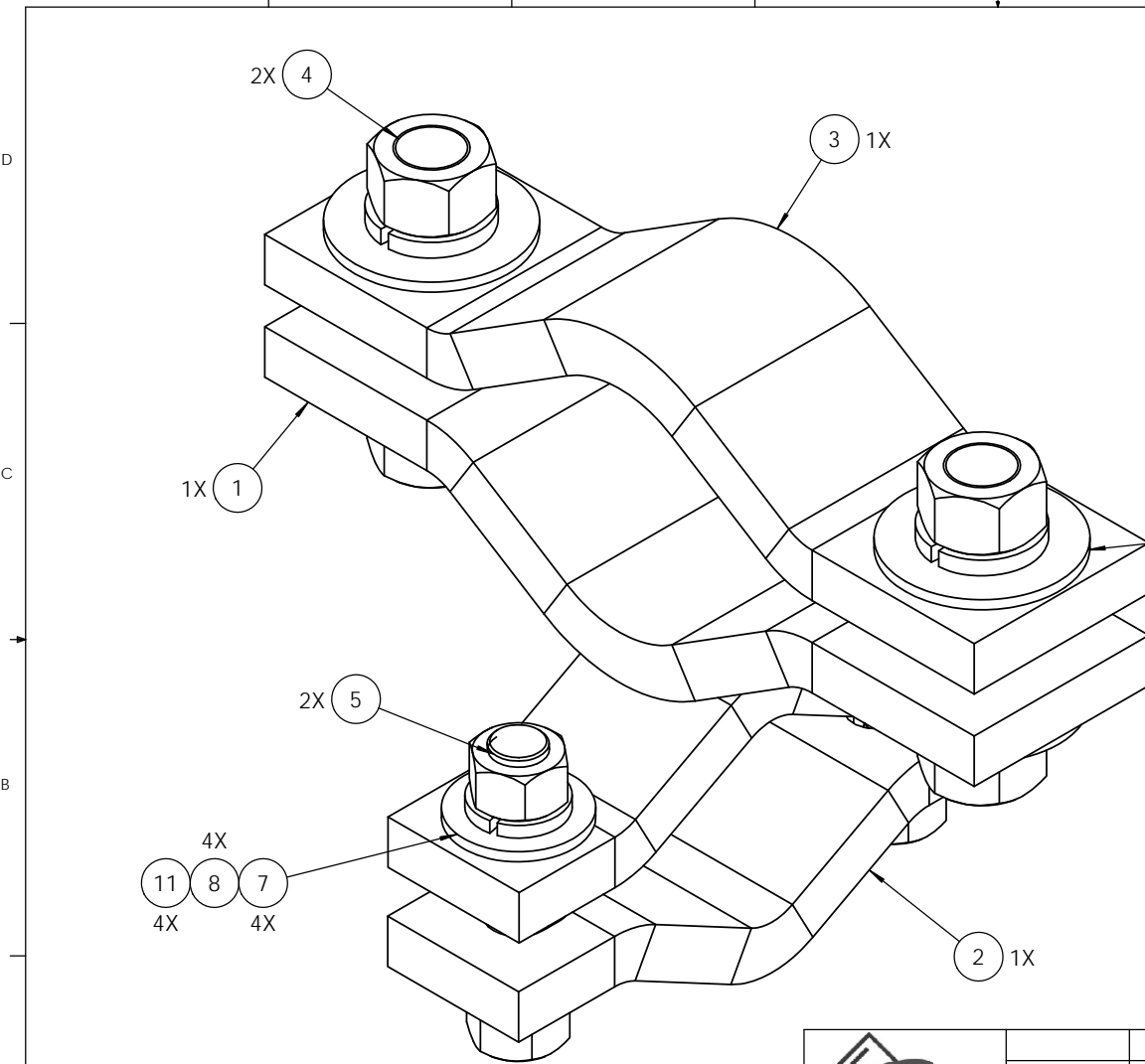

ITEM NO.	PART NUMBER	DESCRIPTION	QTY.
1	K1010KT2	Crossover clamp, 2-3/8" x 5"	1
2	K1000KT6	Clamp Half, 1-1/2" x 5-7/8" x 1/2"	1
3	K1000KT8-534	Half Clamp, Medium 5-3/4" Center	1
4	K2220KT8i	Threaded rod 5/8" x 8", HDG	2
5	K2120KT6i	Threaded rod 1/2" x 6", HDG	2
6	H3012KT58GSA3	Flat washer, 5/8", SAE (A325), HDG	4
7	H3012KT12G	Flat washer, 1/2", HDG	4
8	H3002KT12G	Lock washer, 1/2" HDG	4
9	H3002KT58G	Lock washer, 5/8", HDG	4
10	H2002KT58GA3	Nut, hex heavy 5/8" HDG A325	4
11	H2002KT12GA3	Nut, hex heavy 1/2" HDG A325	4

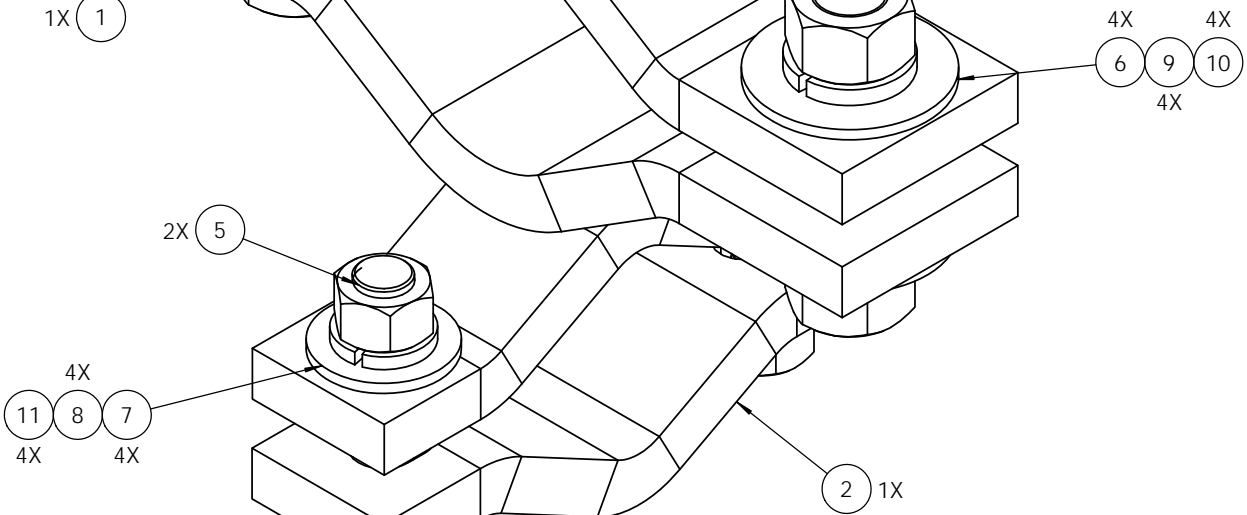

A

**KENWOOD TELECOM**  
 3431 Newby Pointe, Acworth, GA 30201  
 (888) 339-0500 (770) 974-7000 fax

**PROPRIETARY AND CONFIDENTIAL**  
 THE INFORMATION CONTAINED IN THIS DRAWING IS THE SOLE PROPERTY OF KENWOOD TELECOM. ANY REPRODUCTION IN PART OR AS A WHOLE WITHOUT THE WRITTEN PERMISSION OF KENWOOD TELECOM IS PROHIBITED.

UNLESS OTHERWISE SPECIFIED:		NAME	DATE	<b>KENWOOD TELECOM</b>
DIMENSIONS ARE IN INCHES		PQ	10/23/14	
TOLERANCES:		DRAWN		TITLE:
FRACTIONAL: ± 1/32		CHECKED		
ANGULAR: ± 2°		ENG APPR.		Crossover Clamp Kit 2-3/8"-5"
ONE PLACE DECIMAL: ± .06		MFG APPR.		
TWO PLACE DECIMAL: ± .03		Q.A.		SIZE
THREE PLACE DECIMAL: ± .010		COMMENTS:		DWG. NO.
INTERPRET GEOMETRIC TOLERANCING PER:				REV
MATERIAL:				<b>B</b>
FINISH:				K1004KT2
NEXT ASSY	USED ON			SCALE: 1:1
APPLICATION		DO NOT SCALE DRAWING		WEIGHT: 7.90
				SHEET 1 OF 1

8 7 6 5 4 3 2 1