

8 7 6 5 4 3 2 1

D

D

C

C

B

B

A

A

8 7 6 5 4 3 2 1

| ITEM NO. | PART NUMBER | DESCRIPTION | QTY. |
|----------|---------------|--|------|
| 1 | K1672KT-04 | Leg Channel, Inner (ATT Heavys) | 1 |
| 2 | K1690KT-03 | Channel for Sector Frame | 1 |
| 3 | K1610KT-01 | Mount Channel | 1 |
| 4 | K1610KTL-02 | Support Arm - 60" Standoff | 2 |
| 5 | K1610KT-03 | Face Mount | 2 |
| 6 | H7941KT4 | U-Bolt, 1/2-13; 4" Lng; 2-1/2"IL x 2" Thd; HDG | 4 |
| 7 | H1026KT112GA3 | Bolt, 1/2"x1-1/2" (A325) HH HDG | 16 |
| 8 | H3012KT12GSAE | Flat washer, 1/2", SAE (A325), HDG | 24 |
| 9 | H3002KT12G | Lock washer, 1/2" HDG | 24 |
| 10 | H2002KT12GA3 | Nut, 1/2" HH, HDG (A325) | 24 |
| 11 | K2320KT18i | Threaded rod 3/4"x18", HDG, ASTM A193 B7 | 2 |
| 12 | H3012KT34GSA3 | Flat washer, 3/4", SAE (A325), HDG | 4 |
| 13 | H3002KT34G | Lock washer, 3/4", HDG | 4 |
| 14 | H2002KT34GA3 | Nut, 3/4" HH, HDG (A325) | 4 |
| 15 | H1029KT2GA3 | Bolt, 5/8"x2" (A325) HH, HDG | 2 |
| 16 | H3012KT58GSA3 | Flat washer, 5/8", SAE (A325), HDG | 2 |
| 17 | H3002KT58G | Lock washer, 5/8", HDG | 2 |
| 18 | H2002KT58GA3 | Nut, hex heavy 5/8" HDG A325 | 2 |

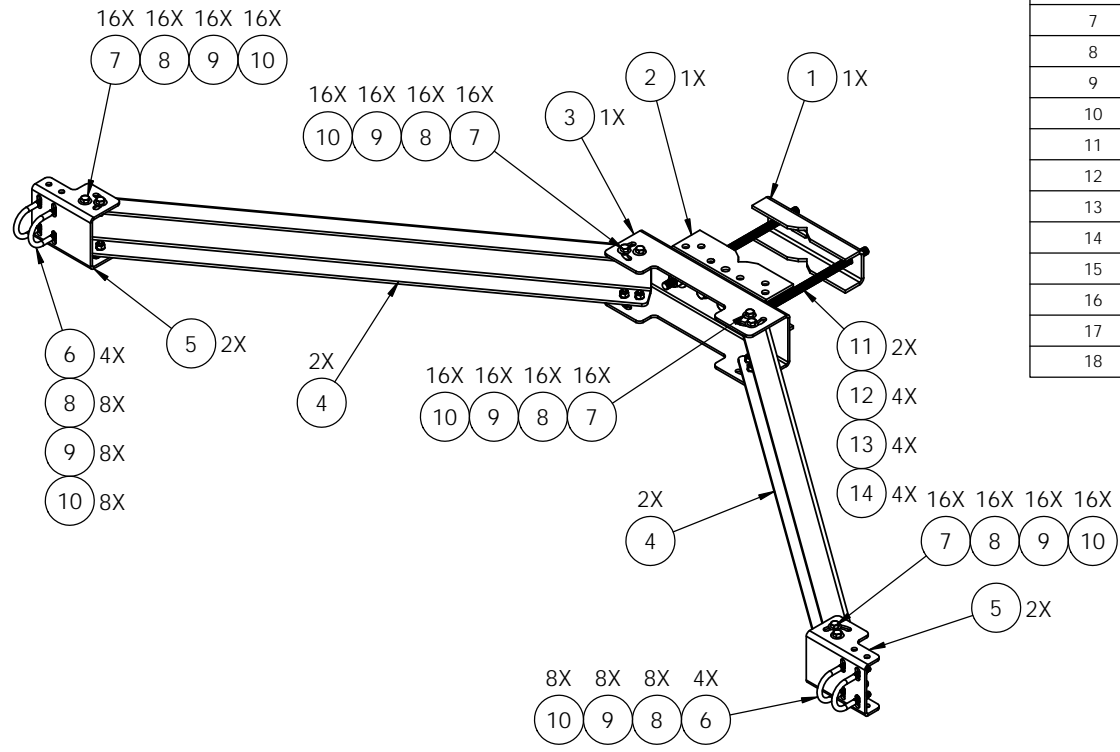

3431 Novis Pointe Acworth, Ga 30101
(770) 975-0500 office, (770) 974-5100 fax

UNLESS OTHERWISE SPECIFIED:
DIMENSIONS ARE IN INCHES
TOLERANCES:
FRACTIONAL: ± 1/32
ANGULAR: ± 2°
ONE PLACE DECIMAL: ± .06
TWO PLACE DECIMAL: ± .03
THREE PLACE DECIMAL: ± .010
INTERPRET GEOMETRIC TOLERANCING PER:
MATERIAL:
FINISH:
DO NOT SCALE DRAWING

| | |
|--------------|---------|
| NAME | DATE |
| DRAWN KAR | 5/11/15 |
| CHECKED | |
| ENG APPR. | |
| MFG APPR. | |

PROPRIETARY AND CONFIDENTIAL
THE INFORMATION CONTAINED IN THIS DRAWING IS THE SOLE PROPERTY OF KENWOOD TELECOM. ANY REPRODUCTION IN PART OR AS A WHOLE WITHOUT THE WRITTEN PERMISSION OF KENWOOD TELECOM IS PROHIBITED.

| | | | |
|-------------|----------|---|--|
| | | TITLE: | |
| | | Sector Frame Reinforcement Kit 60" Standoff | |
| SIZE | DWG. NO. | REV | |
| B | K1610KTL | | |
| SCALE: 1:12 | | FINISHED WEIGHT: 163.30 | |
| | | SHEET 1 OF 1 | |