

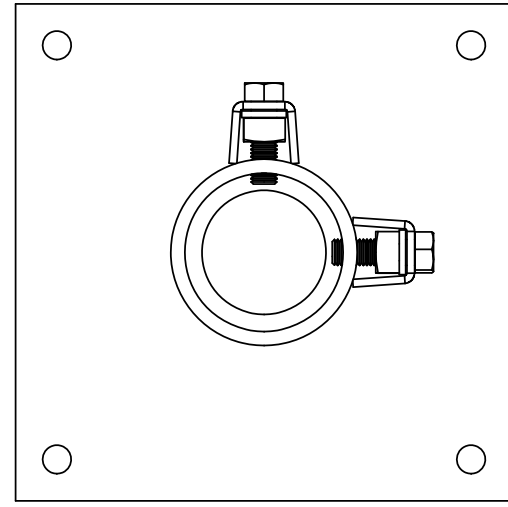

ITEM NO.	PART NUMBER	DESCRIPTION	QTY.
1	H1029KT2GA3	Bolt, 5/8"x2" (A325) HH, HDG	2
2	H3002KT58G	Lock washer, 5/8", HDG	2
3	H2002KT58GSq	Square nut, 5/8" HDG, standard	2
4	K8810KT12HD	Base Shoe for 3.5in OD pipe. 12in x 1/2in plate, 10" pipe SCH80	1

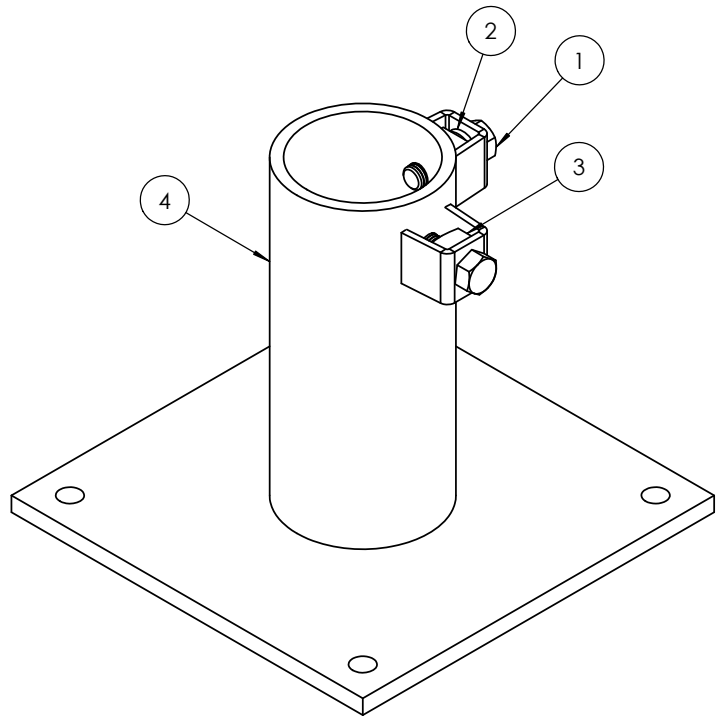

 KENWOOD TELECOM <small>3431 Novis Pointe Acworth, Ga 30101 (770) 975-0500 office (770) 974-5100 fax</small>	UNLESS OTHERWISE SPECIFIED: DIMENSIONS ARE IN INCHES TOLERANCES: FRACTIONAL: ± 1/32 ANGULAR: ± 2° ONE PLACE DECIMAL: ± .06 TWO PLACE DECIMAL: ± .03 THREE PLACE DECIMAL: ± .010	NAME: KAR DATE: 4/11/20	 KENWOOD TELECOM TITLE: Pipe shoe Assembly for 3.5" Pipe, 10" SC80 12"x12"x1/2" Plate	
	INTERPRET GEOMETRIC TOLERANCING PER:	DRAWN: KAR CHECKED: ENG APPR.: MFG APPR.:		SIZE: DWG. NO. P8810KTHDA REV: -
	MATERIAL: FINISH:	PROPRIETARY AND CONFIDENTIAL THE INFORMATION CONTAINED IN THIS DRAWING IS THE SOLE PROPERTY OF KENWOOD TELECOM. ANY REPRODUCTION IN PART OR AS A WHOLE WITHOUT THE WRITTEN PERMISSION OF KENWOOD TELECOM IS PROHIBITED.		SCALE: 1:3 FINISHED WEIGHT: SHEET 1 OF 1
	DO NOT SCALE DRAWING			