

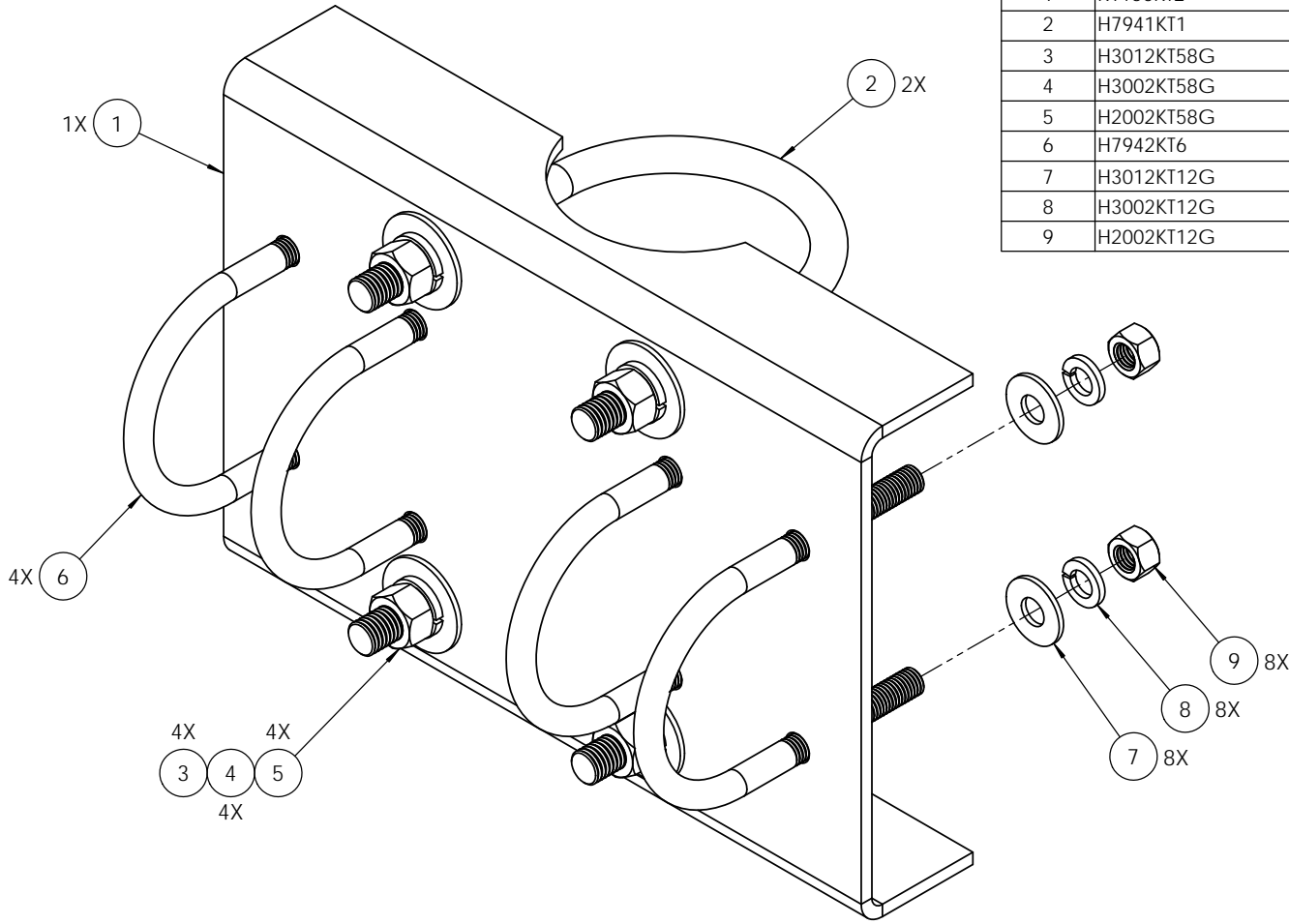

ITEM NO.	PART NUMBER	DESCRIPTION	QTY.
1	K1150KT2	Pipe frame X plate for 36"T-arm	1
2	H7941KT1	U-Bolt, 5/8-11; 7" Lng; 4-5/8" IL; 3" Thd; HDG	2
3	H3012KT58G	Flat washer, 5/8", HDG	4
4	H3002KT58G	Lock washer, 5/8", HDG	4
5	H2002KT58G	Nut, hex std. 5/8" HDG	4
6	H7942KT6	U-Bolt, 1/2-13; 6" Lng; 3.625" IL; 3" thd; HDG	4
7	H3012KT12G	Flat washer, 1/2", HDG	8
8	H3002KT12G	Lock washer, 1/2" HDG	8
9	H2002KT12G	Nut, Hex 1/2" HDG	8





**KENWOOD  
TELECOM**

3431 Novis Pointe Acworth, Ga 30101  
(770) 975-0500 office (770) 974-5100 fax

UNLESS OTHERWISE SPECIFIED:  
DIMENSIONS ARE IN INCHES  
TOLERANCES:  
FRACTIONAL: ± 1/32  
ANGULAR: ± 2°  
ONE PLACE DECIMAL: ± .06  
TWO PLACE DECIMAL: ± .03  
THREE PLACE DECIMAL: ± .010

INTERPRET GEOMETRIC TOLERANCING PER:

MATERIAL:

FINISH:

DO NOT SCALE DRAWING

NAME	DATE
KAR	4/8/15
CHECKED	
ENG APPR.	
MFG APPR.	

**PROPRIETARY AND CONFIDENTIAL**

THE INFORMATION CONTAINED IN THIS DRAWING IS THE SOLE PROPERTY OF KENWOOD TELECOM. ANY REPRODUCTION IN PART OR AS A WHOLE WITHOUT THE WRITTEN PERMISSION OF KENWOOD TELECOM IS PROHIBITED.



**KENWOOD TELECOM**

TITLE: Pipe Frame Hardware Kit For T-Arm

SIZE	DWG. NO.	REV
<b>B</b>	<b>T1719KTA</b>	

SCALE: 1:5 FINISHED WEIGHT: 23.81 SHEET 1 OF 1