

T3203MT - 4 RUN SPLICE

QTY	ITEM	PART NUMBER	DESCRIPTION
1	1	K3203MT	STRAIGHT SPLICE (4) RUNS
1	2	K1028KT1-10	HARDWARE KIT

T3205MT - 8 RUN SPLICE

QTY	ITEM	PART NUMBER	DESCRIPTION
1	1	K3205MT	STRAIGHT SPLICE (8) RUNS
1	2	K1028KT1-10	HARDWARE KIT

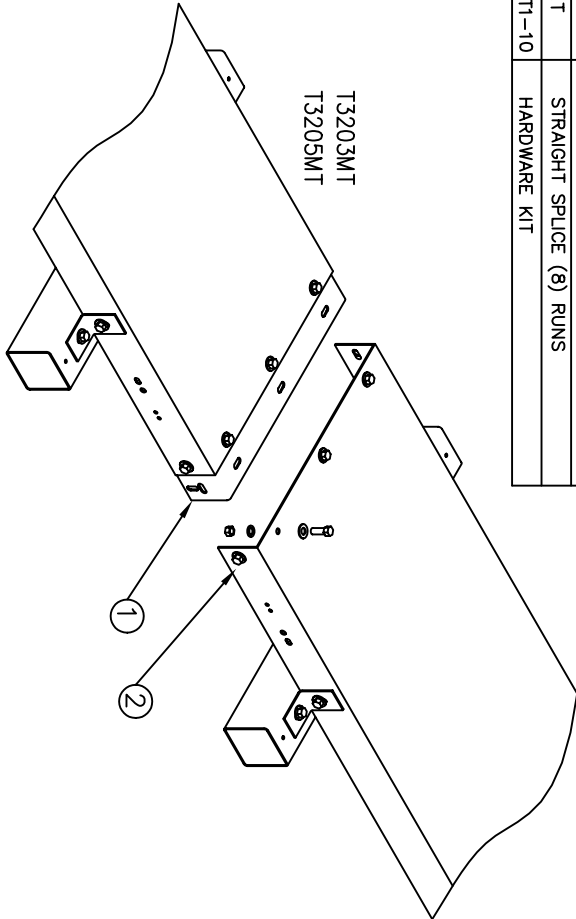

T3206MT - ADJUSTABLE SPLICE FOR 4 RUN PAN

QTY	ITEM	PART NUMBER	DESCRIPTION
1	1	K3206MT	ADJUSTABLE SPLICE (4) RUNS
1	2	K1028KT1-6	HARDWARE KIT

T3207MT - ADJUSTABLE SPLICE FOR 8 RUN PAN

QTY	ITEM	PART NUMBER	DESCRIPTION
1	1	K3207MT	ADJUSTABLE SPLICE (8) RUNS
1	2	K1028KT1-6	HARDWARE KIT

T3209MT - ADJUSTABLE SPLICE FOR 12 RUN PAN

QTY	ITEM	PART NUMBER	DESCRIPTION
1	1	K3209MT	ADJUSTABLE SPLICE (12) RUNS
2	2	K1028KT1-6	HARDWARE KIT

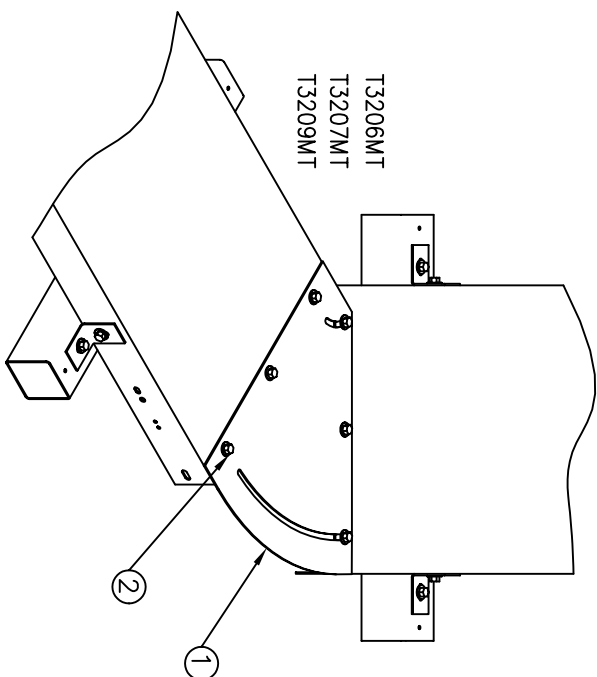



T3403MT4 - EXTENSION/RISER KIT FOR 4 RUN PAN

QTY	ITEM	PART NUMBER	DESCRIPTION
2	1	K3403KT	ANGLE
1	2	K3403KT4	EXTENSION CHANNEL (4 RUNS)
1	3	K3203MT	STRAIGHT SPLICE (4 RUNS)
11	4	H3002KT38G	3/8" GALV LOCK WASHER
11	5	H1028KT114G5	3/8 X 1-1/4" GALV. BOLT
22	6	H3012KT38G	3/8" GALV FLAT WASHER
11	7	H2002KT38G 11	3/8" HEX NUT HDG

T3403MT8 - EXTENSION/RISER KIT FOR 8 RUN PAN

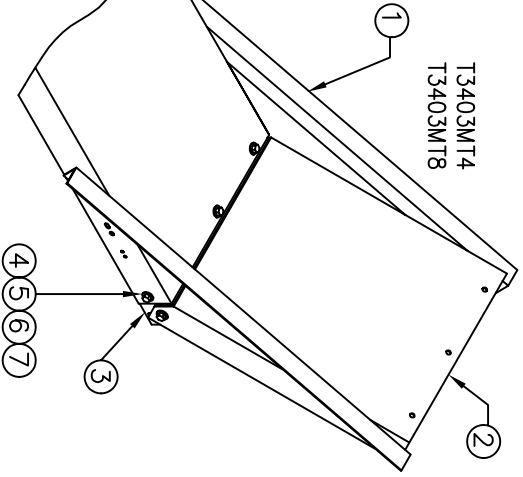
QTY	ITEM	PART NUMBER	DESCRIPTION
2	1	K3403KT	ANGLE
1	2	K3403KT8	EXTENSION CHANNEL (8 RUNS)
1	3	K3205MT	STRAIGHT SPLICE (8 RUNS)
11	4	H3002KT38G	3/8" GALV LOCK WASHER
11	5	H1028KT114G5	3/8 X 1-1/4" GALV. BOLT
22	6	H3012KT38G	3/8" GALV FLAT WASHER
11	7	H2002KT38G 11	3/8" HEX NUT HDG





3431 Nox's Point Acworth, GA 30101
 (888) 439-0500 (770) 974-5100 fax

DRAWN KAA DATE 5/20/05 CHECKED M/JN DATE 5/24/05

TITLE ROOFTOP BRIDGE KIT FITTINGS

DRAWING NO. T320xMT SERIES T3403MT SERIES

REV SHEET 1 OF 1